

CPC-II

Current-to-Pressure Converter

Applications

The CPC-II (current to pressure converter, generation II) is an electrohydraulic pressure-regulating valve control designed for use in positioning single-acting steam turbine valve servos. This CPC's superb accuracy and resolution make it ideal for steam turbine valve control and related turbine speed and load control. The CPC accepts a 4–20 mA pressure demand signal and accurately controls oil pressure to precisely position single-acting steam turbine governor-valves. Precise and stable steam valve control directly relates to improved steam turbine speed and load control and reduced system mechanical wear.

The CPC's redundancy features make it ideal for critical steam turbine applications, where turbine up-time and availability are essential. This converter can be configured to accept redundant pressure demand inputs, from one or two (redundant) controllers, and vote the input to follow. Alternatively the CPC can be configured to accept signals from both its internal oil pressure sensor and an external (redundant) oil pressure sensor, and use the voted healthy signal.

The CPC's robust design (strong actuator, corrosion-resistant material, single moving rotary valve, and self cleaning port design) makes it ideal for challenging applications where dirty or contaminated oil may be present.

Optionally two controllers can be connected to a single CPC in a redundant Master/Slave fashion to allow the turbine to continue to operate if either turbine control fails, or on-line changes are desired. Designed for use in applications requiring full redundancy, optionally two CPCs can be applied in a dual-redundant fashion, simplifying the entire system and control wiring.

Description

The CPC is an electrohydraulic pressure-regulating valve control that utilizes a very accurate internal pressure sensor and PID controller to precisely control steam turbine valves. The CPC consists of a valve-actuator assembly, pressure sensor, and electronic driver module. The unit's driver module accepts one (or two) 4–20 mA pressure setpoints and compares these setpoints to the sensed oil pressure, to accurately control turbine valve oil pressure.

The CPC controls oil pressure by porting supply-oil to its control-oil output port (turbine valve control oil) or back to the system supply tank. This converter's special PID architecture allows it to perform very stable pressure control during normal conditions, and respond in milliseconds to desired valve step changes during system or plant transients. As a means of protecting the turbine, an internal valve-return-spring forces the CPC to a failsafe position (port oil to drain) and safely close turbine control valves upon any internal unit failure (electrical input power failure, pressure sensor failure, processor failure, etc.).



- Oil contamination resistant
- Precise fluid pressure control
- Stable & linear valve control
- Included valve linearization table
- Redundant inputs/sensors for critical applications
- Accepts signals from redundant controllers
- Redundant (dual) CPCs (Master/Slave) functionality
- Standard mounting and hydraulic connections
- Self cleaning valve algorithm
- Status & health indication
- Control pressure readout
- Software service tool with trending
- Certified for North American Hazardous Locations
- Compliant with applicable CE Directives—ATEX, Machinery, PED, and EMC
- Certified for use in explosive atmospheres within the Russian Federation

The CPC is factory and/or field configurable via a computer-based service tool. The CPC's PCI Service Tool uses a simple user-friendly format to allow users to easily configure, calibrate, and adjust all internal functions and PID control settings. The CPC includes a 4–20 mA output channel to indicate control oil pressure level, and unit alarm and shutdown relay outputs for use as unit health and status indications into the system controller or plant DCS.

Features

A Manual Stroke function allows users to manually stroke the CPC output pressure (turbine valve position) locally at the unit, via an internal Manual Stroke Screw. This local manual stroke function is designed with built in security logic to protect the users from un-intentional use of this function during normal operation. Manual Stroke capability is also available via remotely or locally via the CPC's computer based PCI Tool.

Since flow through single and staged inlet steam valves tend to be non-linear throughout their flow range, turbine controls are typically de-tuned to compensate for instability or sluggish control points throughout this range. As a way of allowing turbine control optimization, the CPC includes an eleven-point linearization table to allow turbine OEMs or users to compensate for poor valve linearization by digitally linearizing the control to valve flow relationship.

Because many turbine users utilize redundant pressure converters to increase system reliability, and because these type of applications are prone to silting build-up problems in the slave unit, a special "Silt Buster" routine is also configurable to routinely remove internal silt build-up.

Accessories

A standard steel adapter plate is available to allow the CPC to easily interface with systems designed for Voith I/H converters.

Specifications

Performance

Accuracy: < $\pm 0.2\%$ of full range
 Repeatability: 0.1% of full range
 Temperature Drift: < $\pm 0.01\%$ of full range /°C
 Pressure stability: < $\pm 2\%$ of setpoint
 Failsafe Operation: Internal return spring forces Control Port oil to drain port on loss of power or detected failures
 Configuration: Computer based Service Tool (RS-232 communications port)

Physical

Dimensions: See outline drawings
 Height x Width x Depth: Approx. 290 x 270 x 270 mm
 Weight: Approximately 25 kg (55 lb) without oil
 Fluid Ports: See outline drawings
 Mounting: Any attitude, Four M10 threaded holes, 23 mm deep, on the face with the hydraulic ports.
 Adequate support must be provided for the unit.

Environmental

Operating Temperature Range: –40 to +85 °C
 Hydraulic Supply Temperature: –40 to +85 °C
 Immunity: EN61000-6-2 (2005)
 Emissions: EN61000-6-4 (2007)
 Shock: US MIL-STD-810C method 516.2, procedure 1 (10 G Peak, 11 ms duration, saw tooth waveform)
 Vibration: US MIL-STD 810F, M514.5A, Cat. 4 (0.015G²/Hz, 10–500 Hz, 1.04 Grms)
 Ingress Protection: IP56 per EN 60529

Electrical

Input Supply: 18–32 Vdc @ 1.5 A steady state, 8 A peak (100 ms)
 Analog Input Signals: Isolated 4–20 mA (250 Ω input impedance)
 Analog Output Signal: 4–20 mA – maximum external load: 300 Ω , Accuracy = $\pm 1\%$ of full scale
 Discrete Inputs: Optically Isolated (requires 24 Vdc wetting voltage)
 Discrete Output Rating: 1 A @ 30 Vdc
 Service Tool Port: RS-232 communications via straight-through serial cable

Hydraulic

Fluid Types: Mineral or synthetic based oils may be used.
 Contact Woodward for specific oil recommendations.

CPC-II Model	Maximum Input Supply Pressure	Maximum Output Pressure Range*
10 bar 9907-1103 9907-1106	25 bar (363 psi)	0–10 bar (0–145 psi)
25 bar 9907-1100 9907-1102	25 bar (363 psi)	0–25 bar (0–363 psi)
10 bar 9907-1105	10 bar (145 psi)	0–10 bar (0–145 psi)

* **Note:** The recommended maximum output pressure is less than 70% of the supply for the best dynamic performance.

Recommended Filtration: 24–40 μm nominal, β_{75} or ISO 20/16 Class

Recommended Viscosity 20 to 100 centistokes
 Specific Gravity: 0.6 to 1.0

Flow Capacity: Depends on viscosity and pressure difference (see Figure 3)

Return/Drain Pressure: Maximum 2 bar (29 psi)

Regulatory Compliance

European Compliance for CE Marking:

EMC Directive: 2004/108/EC

ATEX Directive: 94/9/EC Zone 2, Category 3, Group II G Ex nA II T3; and LCIE 08 ATEX 6123 Zone 1, Category 2, Group II G Ex d IIB T3 and LCIE 08 ATEX 6124 Zone 2, Category 3, Group II G Ex nA IIC T3

Other European/International Compliance:

(Compliance with the following European Directives or standards does not qualify this product for application of the CE Marking.)

Machinery Directive: Compliant as a component with 98/37/EC

Pressure Equipment Directive: Compliant as "SEP" per Article 3.3 to 97/23/EC

GOST-R: Certified for use in explosive atmospheres within the Russian Federation per Gost-R certificate POCC US. ГБ04.Б01140 as 1ExdIIBT3X and 2ExnAIIIT3X

North American Compliance:

CSA: CSA Certified for Class I, Division 1, Groups C and D and Class I, Division 2, Groups A, B, C, and D, T3 at 85 °C Ambient for use in Canada and the United States.

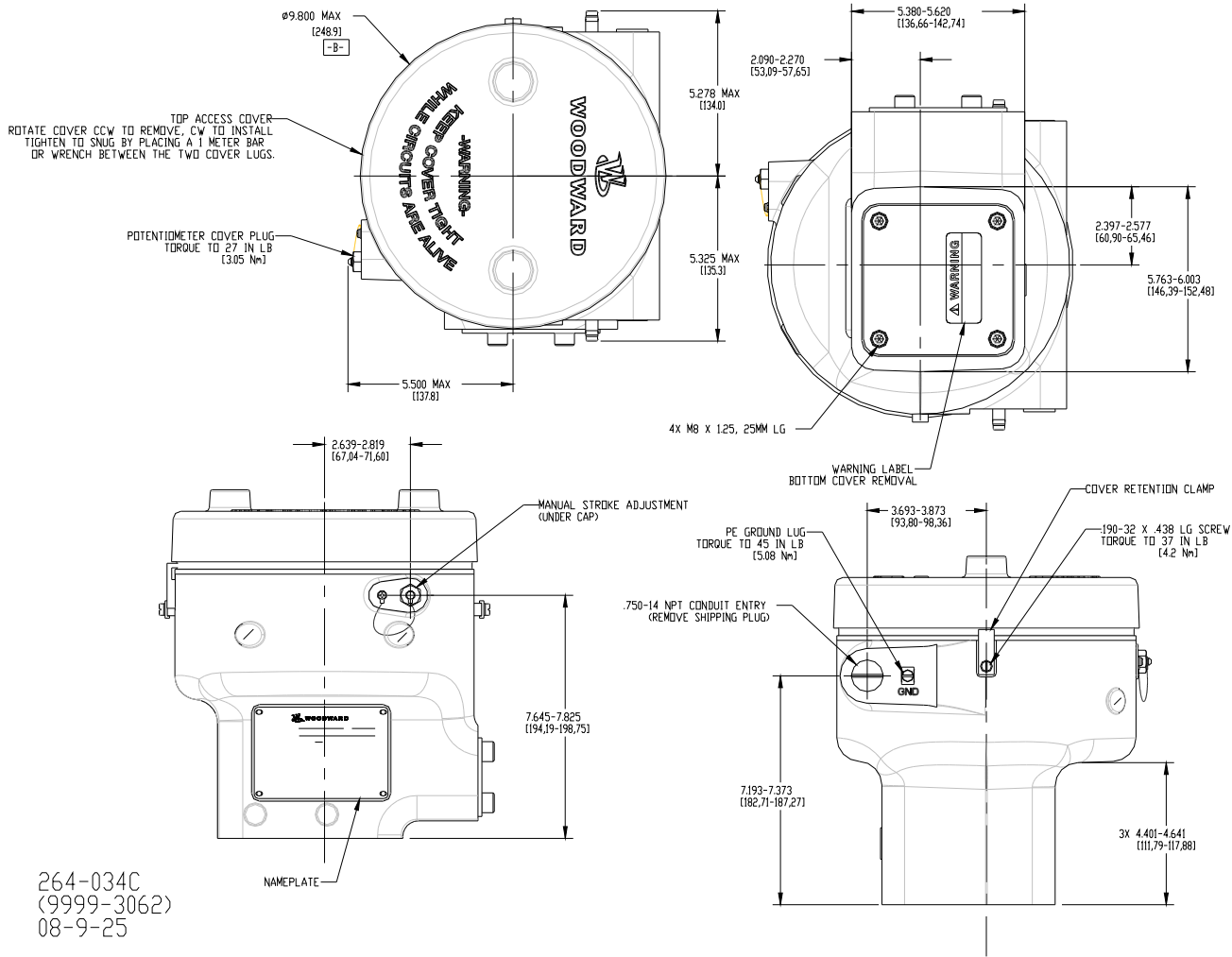

Figure 1. CPC-II Outline Drawing

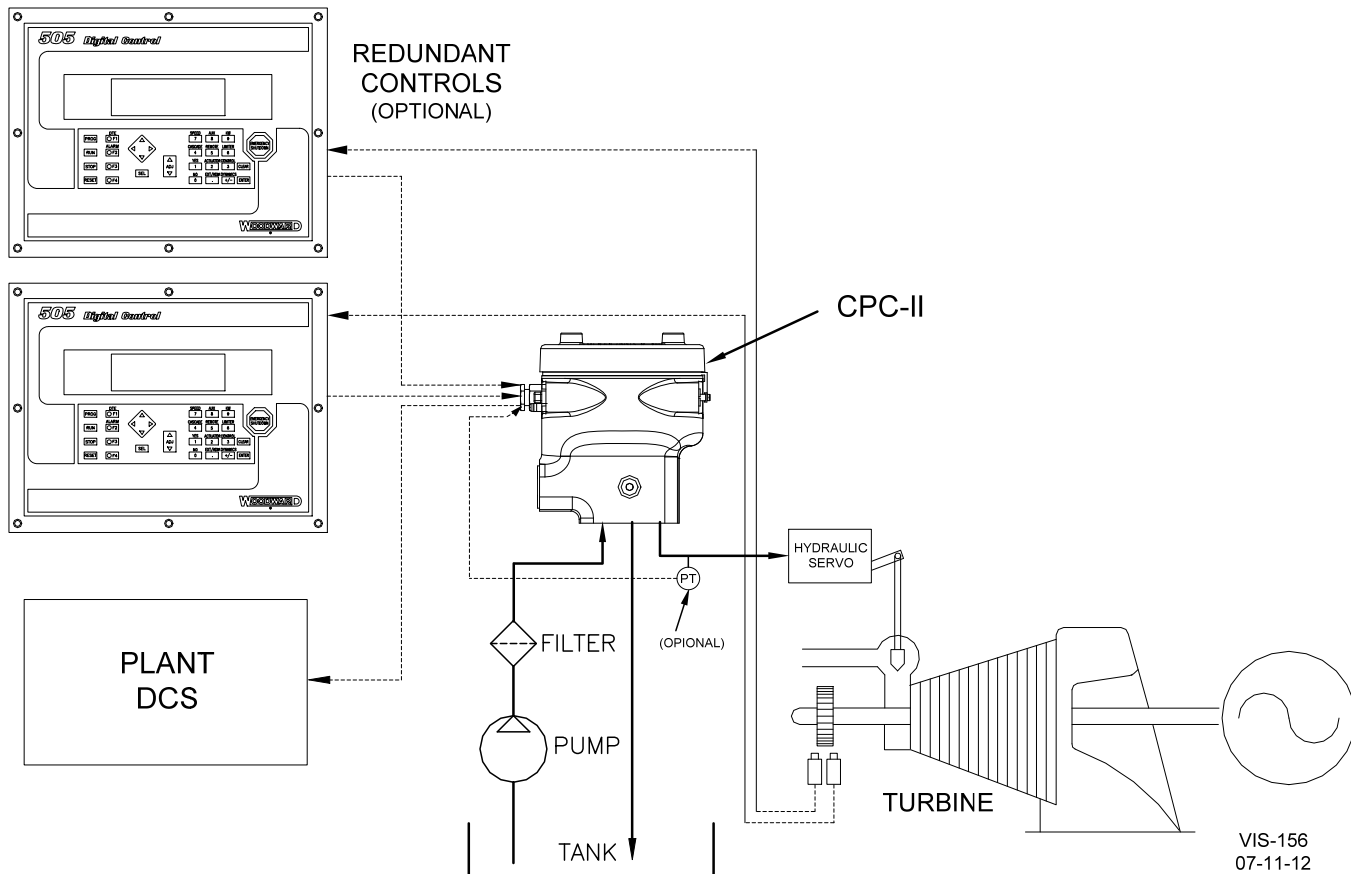
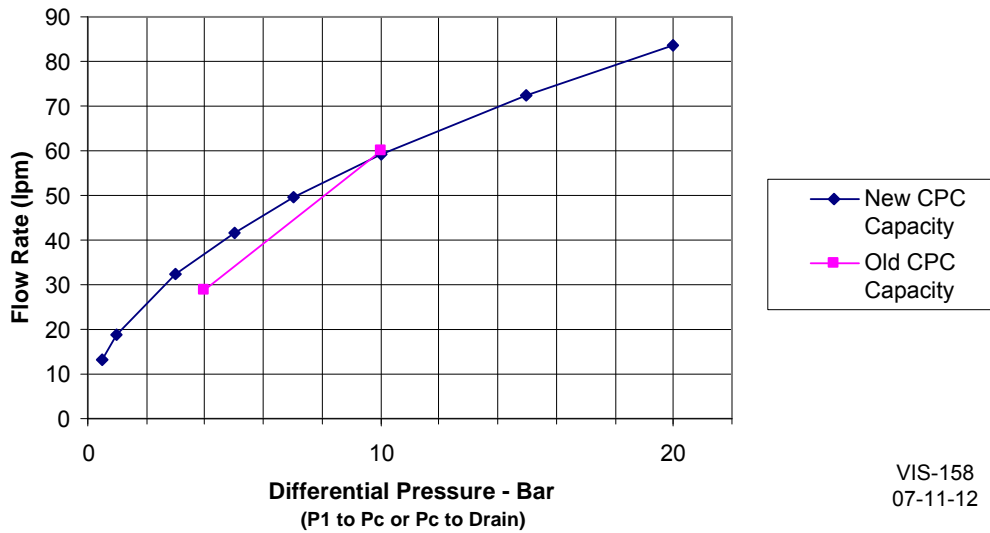
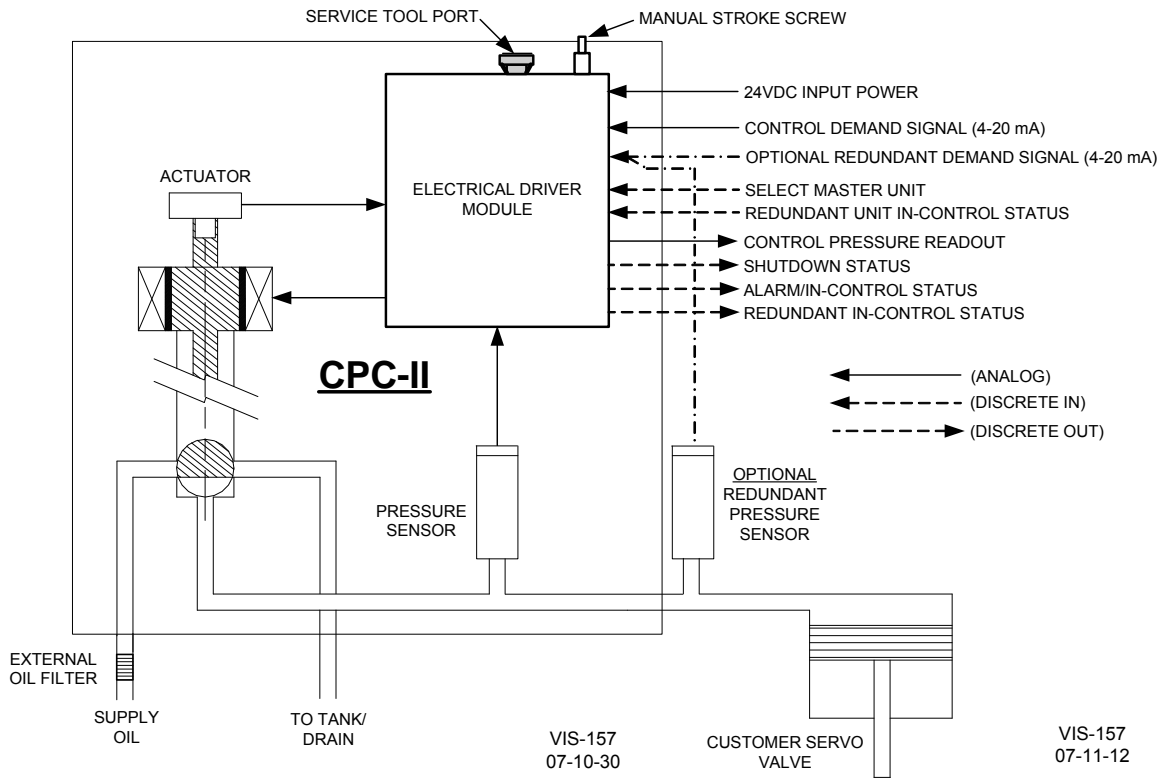

Figure 2. Typical Redundant Control System using a CPC



VIS-158
07-11-12

Figure 3. CPC-II Flow Capacity



VIS-157
07-10-30

VIS-157
07-11-12

Figure 4. CPC-II Interface Schematic

Technical Manual: 26448



PO Box 1519, Fort Collins CO, USA 80522-1519
 1000 East Drake Road, Fort Collins CO 80525
 Tel.: +1 (970) 482-5811 ♦ Fax: +1 (970) 498-3058
www.woodward.com

Distributors & Service

Woodward has an international network of distributors and service facilities. For your nearest representative, call the Fort Collins plant or see the Worldwide Directory on our website.

This document is distributed for informational purposes only. It is not to be construed as creating or becoming part of any Woodward Governor Company contractual or warranty obligation unless expressly stated in a written sales contract.

© Woodward 2008, All Rights Reserved

For more information contact: